

# PLANNED MAINTENANCE

## "LOCKOUT PRIOR TO MAINTENANCE"

STATION #45LH  
S5S PROJECT  
BODY

2/21/2002

PS0018

### LUBRICATION

- S ① Check lubricator & fill as required with Tribol ATO-100LS.
- S ② Grease robot as required with Tribol MPG-00.

### VISUAL INSPECTION

- S ③ Visually inspect the robot, controller, workcell and the surrounding area. During the inspection make sure all safeguards are in place and the work envelope is clear of personnel.
- D ④ Ensure cooling valve is open.
- W ⑤ Check teach pendant cable for excessive twisting. Unwind as required.
- W ⑥ Check ventilation port on controller for dust and clean as required.
- D ⑦ Check hoses and fittings for tightness and cracks. Repair as required.
- D ⑧ Check tip dresser cutter blade for wear and repair or replace as required.
- D ⑨ Check battery case cap to ensure it is secure and for prevention of contamination.

### CRITICAL TOOLING

- S ⑩ Inspect all flex cables in workcell for fatigue.
- W ⑪ Physically check wrist for excessive play.
- W ⑫ Check weld gun for wear & cracks or other evidence of thermal breakdown or damage.
- S ⑬ Dress tips as schedule dictates.
- S ⑭ Record all information on master cell maintenance sheet.

### CLEANING

- D ⑮ Clean any residue that may accumulate on robot.
- W ⑯ Clean all visual containers, i.e.; air, oil.
- W ⑰ Clean teach pendants.
- D ⑱ Clean tip dressers.

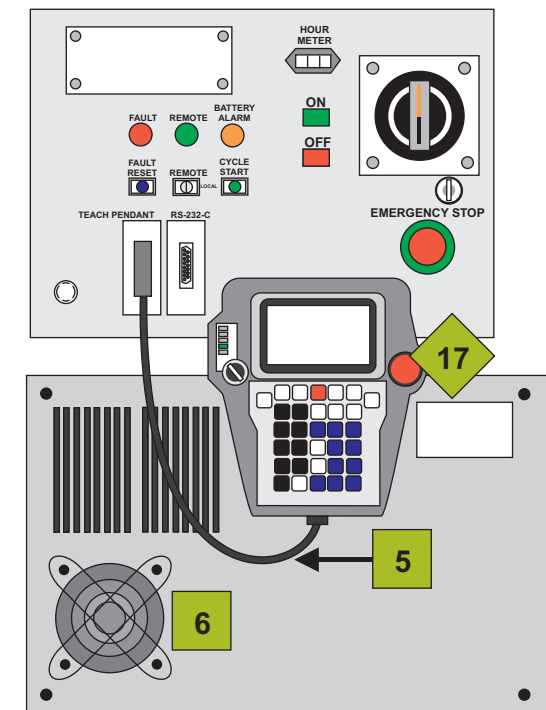
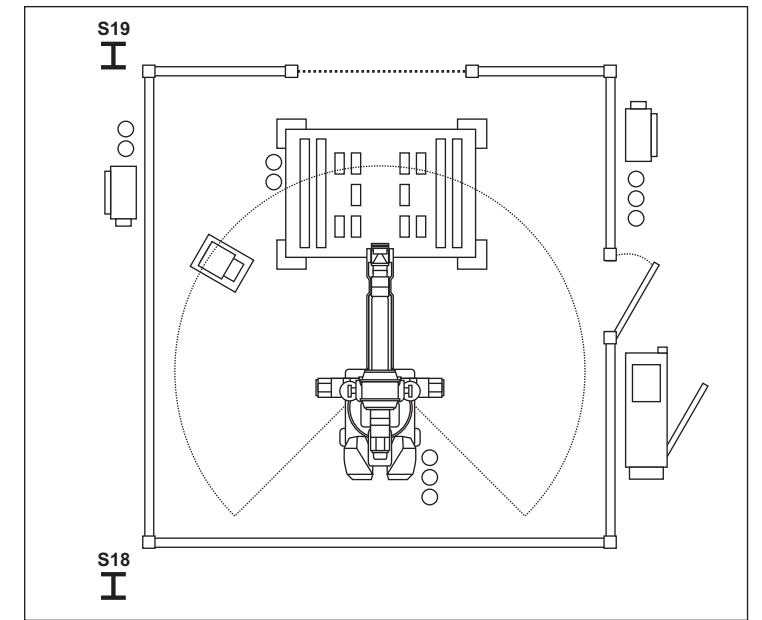
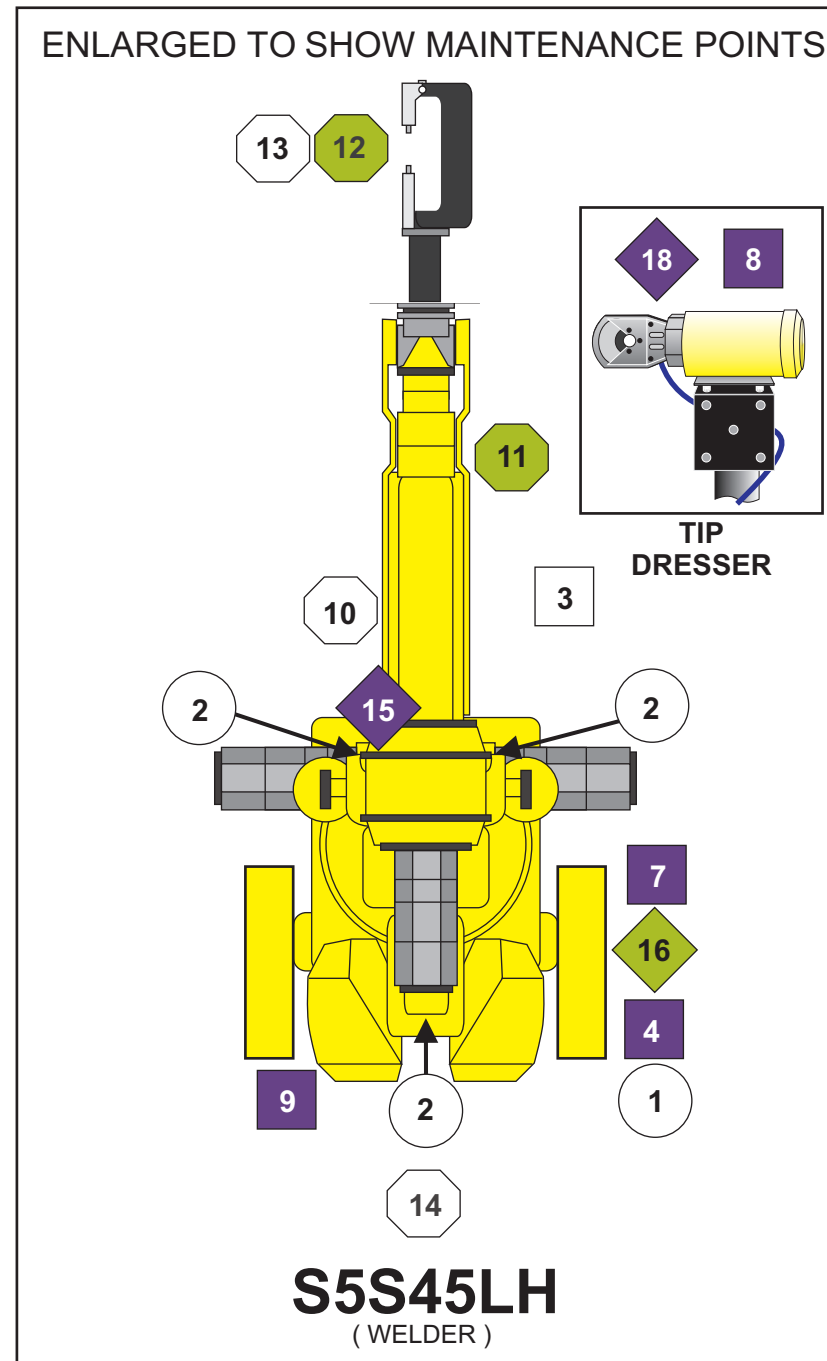

○ = Shift

● = Daily

● = Weekly

For Repairs or Replacements, Please Contact Premier Autoworkers, Inc. at (800) 266-7361